

Service • Quality • Innovation

2024 Products & Capabilities Catalog





TTI

Service • Quality • Innovation

Table of Contents

About Us	4
Industries We Serve	4
Commitment to Excellence	5
PowerGuard Filter Elements	8
Patented SmartMedia Technology	10
StaticGuard Media	11
Water Absorptive Media	12
Stainless Steel Wire Mesh	13
Insoluble Removal Media	13
TT200 Series Elements	14
Spin-On Elements	15
Filter Carts	16
Fuel Cleanliness	17
PowerGuard Housings	18
PowerBreather Desiccant Breathers	22
Standard PowerBreather	23
Titan PowerBreather	24
TitanBlock Powerbreather	26
Rebuildable PowerBreather	27
PowerBreather Adapters	28
Cross Reference & Sizing Tools	30
Contact Us	31

About Us

TTI is the next generation innovator in the filtration industry, focused on delivering new technologies that create significant value for our partners and customers.

Our ongoing success has allowed for the recent addition of a manufacturing facility, lab, and sales office in Germany as well as a dedicated sales office in Costa Rica. These investments, along with our Denver headquarters, put TTI in a fantastic position to continue our growth story on a global scale.

Primary Industries We Serve



Hydraulic Systems



Power Generation



Pulp & Paper



Steel Manufacturing



Oil & Gas



General Industrial

Commitment to Excellence

Service • Quality • Innovation

These three core values have defined our company and culture from the very beginning. That's why we put them in our logo!

Service

Our team works hard to ensure that every customer receives the ideal filtration products for their needs. Whenever you call TTI, you'll be answered by a real person ready and eager to help. The best part is, we ship all of our products in just days, rather than weeks or months like the competition.

Quality

Our products are manufactured in the USA, or Germany for our European friends, and inspected for 100% quality assurance. With world-class materials and production processes, we guarantee that TTI customers always receive the best and longest-lasting filtration products available anywhere.

Innovation

While other top filtration companies have been content to make the same products in the same ways for 50+ years, TTI is constantly patenting new designs, expanding our product lines, and looking for ways to push our industry forward. Whatever your specific needs, our engineering team will work with you to find (and perhaps invent) a solution.



Performance Testing Capabilities

TTI's new headquarters in Germany is equipped with state-of-the-art testing and production infrastructure, positioning us as pioneers in filtration product innovation. With a keen focus on surpassing industry benchmarks, we have partnered with IBS FILTRAN* and invested in advanced equipment to ensure rigorous quality standards and continuous improvement across our product line.

*IBS FILTRAN is the global market leader for automotive transmission filtration systems. As a Tier 1 supplier, IBS FILTRAN serves nearly all industry OEMs worldwide with IATF 16949, ISO 14001, and ISO 50001 certification.

Importance of Filtration Product Testing

Testing industrial filtration products is paramount to ensuring their efficacy and reliability in diverse operational environments. Rigorous testing protocols are essential to validate performance metrics such as filtration efficiency, particle capture rates, pressure drops, and durability under real-world conditions.



6

Efficiency Test Stands

Testing:

- ISO 16889 – Multi-Pass efficiency and DHC test
- ISO 4548-12 – Filtration efficiency oil filters for internal combustion engines
- SAE J 1985 – Initial single-pass efficiency test
- TFEM – Clean up efficiency test acc. to SAE 2001-01-0372
- ISO 2941 – Element collapse test

Hardware Features:

- 3-Loop-Hydraulic-System with two main pumps to ensure turbulent flow conditions over a wide flow range
- Test operation with static and dynamic volume options
- Pressure, suction, and bypass filter modes
- SLS and HCB particle counting system for a wide range of particle counting and test dusts

Flow Characteristics Test Stands

Testing:

- ISO 3968 – Evaluation of differential pressures versus flow characteristics

Hardware Features:

- 2-Loop-Hydraulic-System with two main pumps to ensure good decoupling of the thermal mixing and simultaneous quick adjustment of measured volume flow
- Wide volume flow and temperature range
- Static and dynamic volume flow options
- Pressure and suction filter modes



Climate Cabinet

Hardware Features:

- Temperature range: -70°C up to +180°C
- Humidity range: 10% up to 98% RH
- Dew point range: -10°C up to +94°C
- Test room volume: 350L
- 2.2K/min temperature change speed with 55kg mass for cooling and heating within the temperature range
- 1.5K/min temperature change speed with 110kg mass for cooling and heating within the temperature range

Additional equipment

- **Digital Video Microscope:** 2-Lens system with a wide range of magnification and features for 3D surface images and dimensional measurement
- **Burst Pressure Test Stand:** Test of weld seamed plastic components, pressure range from 0 up to 60bar
- **Universal/Tensile Testing Machine ISO 527:** Determination of tensile properties
- **Air Permeability Test Stand ISO 9237 and ASTM D 737:** Determination of the air permeability of textiles
- **Bubble Point Test Stand ISO 2942:** Verification of fabrication integrity and determination of the first bubble point
- **Technical Cleanliness Test Room ISO 16232**

PowerGuard™ Filter Elements

All TTI PowerGuard filters are produced using DuoGlass media, providing a significant performance upgrade over competing products. Protect your systems and fluids with world-class filter elements that ensure longer filter life, higher dirt holding capacity, and reduced pressure drops.



Protect Your Productivity with PowerGuard

Exceptional Filtration Efficiency: Our proprietary DuoGlass media combined with cutting-edge production methods allow PowerGuard filters to capture even the smallest particles, safeguarding your machinery against the detrimental effects of contamination.

Extended Equipment Life: By preventing the ingress of harmful contaminants, PowerGuard filters prolong the service life of your machines and save you from costly repairs or replacements.

Customized Solutions: We understand that every plant and industrial facility is unique. That's why we offer over 40,000 crosses of PowerGuard filters tailored to suit diverse applications, ensuring a perfect fit for your specific needs.

DuoGlass Media

Benefits Of Our Dual Phase Media Over Conventional Single Phase Media:

- Reduced pressure drops and increased dirt holding capacity over Single Phase Media
- Graded density creates a built-in pre-filter layer for every cartridge
- Beta 1000 efficiencies at 1µm, 3µm, 6µm, 10µm, 25µm, and 40µm

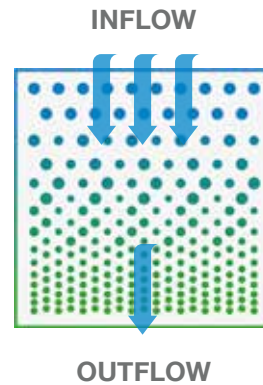

Patented SmartMedia™ Technology

Maximize your uptime by maintaining optimal system pressure and cleanliness with this innovative and drop-in ready parallel flow solution.

TTI SmartMedia filters are ideal for systems with cold start-ups and excel at fighting varying sizes of particulate contamination, high or fluctuating viscosity, and much more. They also offer exceptionally low pressure drops for most hydraulic, lubrication, or bulk fluid transfer systems.

Major Benefits of SmartMedia:

- Up to 35% Longer Filter Life
- Up to 35% Lower Initial Pressure Drop
- Drop-In Solution for Existing Applications
- Patent Protected Design

Ideal Industries for SmartMedia:

- Power Generation & Transmission
- Steel Manufacturing
- Pulp and Paper Mills
- Oil & Gas

Ideal Applications for SmartMedia:

- Cold Startup Conditions
- High Viscosity Fluid
- High System Differential Pressure
- Fluid Pulsation
- Equipment Upsets



StaticGuard™ Static Dissipative Media

StaticGuard media allows static potential to dissipate from filter elements. Electrostatic Discharge (ESD) is static electricity that discharges from filter elements, through the filter media, and to the filter housing. ESD can degrade fluids, increase varnish potential, burn holes through filter media, and lead to hazardous conditions.

If hazardous conditions occur, this may result in explosions in headspace and the destruction of sensitive electronics. If holes are burned through the filter media, fluid will bypass filtration altogether, leading to a massive reduction in oil cleanliness.

To combat these dangers, StaticGuard media utilizes a proprietary mixture of conductive fibers within the element composition, ensuring stable properties and performance throughout the life of the filter. There is minimal aging or loss of conductivity with high heat or oil exposure compared to other coated filter media on the market.



Benefits of StaticGuard Media

- Increased System Uptime
- Maximized Fluid and Lubricant Health
- Maximized equipment protection against damage

While traditional strainer filters do help prevent static discharge, they offer no protection against the inevitable damage, downtime, and profit loss caused by system contamination.



Water Absorptive Media

The PowerGuard™ Water Absorptive media option removes both free and emulsified water, along with the standard DuoGlass media benefits of superior filtration efficiency and higher dirt holding capacity.

Benefits of Water Absorptive Media

Long-term benefits of reducing the water content within systems:

- Increased System Uptime
- Maximized Fluid and Lubricant Health
- Extended System Service Life

Water Holding Capabilities By Element

Moisture content in PPM x Amount of Fluid in Gallons x 0.000128 = oz of water content

Moisture content in PPM x Amount of Fluid in liters x 0.000001 = liters of water content



TTI Element: TT75S-8-*CWA*
Water Capacity: 11oz / 0.330L

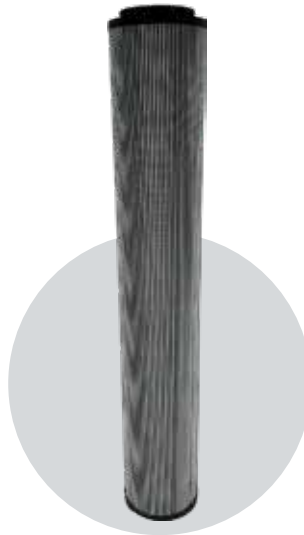

TTI Element: TT207-36-*WA*
Water Capacity: 180oz / 5.32L



TTI Element: TT8314-39-*WA*
Water Capacity: 180oz / 5.30L



TTI Element: TT9600-8-*WA*
Water Capacity: 11oz / 0.33L

Stainless Steel Wire Mesh

Wire mesh media is vital to the preventative maintenance of numerous hydraulic and lubrication applications, providing an efficient and reliable filtration solution. Constructed with robust stainless steel, this filtration media offers exceptional durability, ensuring long-lasting performance even under challenging conditions.

Benefits of Wire Mesh Media

Widely preferred in industries such as steel manufacturing, mining, oil and gas, and fracking, Stainless Steel Wire Mesh is ideal for rugged applications with specific filtration requirements.

Available in 25, 50, 74, and 149µm ratings, Stainless Steel Wire Mesh serves as an extra-durable and open option to TTI's standard DuoGlass.

Ideal Applications for Wire Mesh Media

- Water glycol
- High viscosity lubricants
- Gear oils
- Suction strainers



Insoluble Removal Media

The PowerGuard™ Insoluble Removal media option protects against particulate contamination, water, insoluble oxidation by-product, and varnish.

Benefits of Insoluble Removal Media

Long-term protection against the toughest contaminants:

- Fine Particulate < 1 micron
- Insoluble Oxidation By-Products
- Water
- Varnish



While traditional filter media is effective at removing standard particulates, it provides no assistance removing fine particulates, insoluble particulates, or varnish.

PowerGuard™ TT200 Series Elements

TTI's flagship TT206, TT207 & TT208 series elements deliver greater dirt holding capacity, lower initial pressure drops, and longer filter service life compared to competing products.

They accomplish this by incorporating our proprietary DuoGlass media along with a double external o-ring design that creates a unique sealing arrangement, guaranteeing you will meet your ISO cleanliness goals without the concern of dirty fluid bypassing the filter.



The Pinnacle of Industrial Filter Element Design

All TTI TT200 series filter elements are configured with a coreless design and a permanent post supplied within the filter assembly. This coreless design provides an increased effective surface area of the element, as well as making installation and removal as efficient and user-friendly as possible.

Another benefit of our coreless construction design is that it is exceptionally eco-friendly compared to our competitors – reducing waste to the landfill, allowing the spent filter elements to be incinerated, and reducing shipping weight for replacement elements.

TT206: The TT206 series elements are manufactured standard with a 25 PSI bypass valve integrated in the element end cap.

TT207: The TT207 series elements are manufactured standard with a 50 PSI bypass valve integrated in the element end cap.

TT208: The TT208 series elements are manufactured with no bypass valve which is ideal for critical applications where fluid integrity is paramount.

Innovative Bypass Valve Design

Our TT200 series bypass valves are built directly into the elements, creating a fail-safe characteristic that both the element and bypass valve are replaced when the element reaches its terminal differential pressure. This element-integrated design is a superior option to industry standard bypass valves, which are incorporated into the housing and not replaced when the element is removed, resulting in degradation and failure over time due to harsh conditions and contamination.

PowerGuard™ Spin-On Elements

PowerGuard Spin-On Elements are used to clean hydraulic fluids and lubricants in pressurized fluid management systems. Spin-on canisters have an integrated pleated filter element. When the filter becomes clogged with contamination, the canister is simply unscrewed and replaced.

Benefits of Spin-On Elements

Industry-leading performance available in all standard micron ratings:

- Steel wire support layer for optimal strength
- Rugged 200 PSI maximum working pressure
- Available in a water absorptive grade
- Compatible with both our filter carts and competing brands



TTI PowerGuard™ Filter Cart

A portable filtration solution for decontaminating systems as well as transferring oil and lubricants.

Applications

- Clean-up of contaminated systems
- Treatment of new or repaired systems
- Pre-filtration of new oil
- Directly transfer oil without exposing it to contaminants



Fuel Cleanliness

TTI's trifecta of product lines for bulk fuel cleanliness helps you avoid unexpected shutdowns by polishing your diesel fuel to keep it clean and dry.



Importance of Proper Bulk Fuel Filtration

Not too long ago, diesel engines were simple, inefficient, and burned as much as 5,000 parts per million of high sulfur fuel. Today's high efficiency diesel engines require fuel to meet stringent emission standards and ISO cleanliness levels of 18/16/13, with a water content of less than 0.05%.

Some of the primary dangers to bulk fuel cleanliness:

- Moisture can cause low point suction conditions
- Thermal events can cause moisture and condensation in bulk tanks
- Bacteria, fungi, and algae can cause injector/engine failures
- Reservoir contamination can cause rust and other corrosion

How TTI Protects Your Fuel from Moisture and Contamination

Our diesel fuel polishing technology exceeds manufacturer cleanliness standards by removing particulate, sludge, rust, and microbial contamination — regularly exceeding 2-micron absolute filtration to ISO16889 and removing water to less than 75 PPM.

TTI Fuel Coalescers

Engineered for reliability and performance, our coalescers excel at separating even the tiniest water droplets from fuel. This helps maintain the integrity of your systems, prevents corrosion and microbial growth, and minimizes maintenance costs.

Whether you work in industrial settings, transportation fleets, or remote operations, TTI fuel coalescers ensure that your diesel and bulk fuel remains clean, dry, and ready for seamless operation, even in the most demanding environments.



**Reservoir Head
Space Desiccant
Breathers**



**Diesel Fuel
Coalescers**



**Filters and
Housings**

PowerGuard™ Filter Housings

Built with top-quality materials and engineered to excel in any environment, TTI Filter Housings stand as the pinnacle of reliability and performance. Our comprehensive range ensures a perfect fit for a diverse range of industrial applications, providing a reliable foundation for your critical assets.



PowerGuard™ TTHH 100 Series Simplex Housings

TTI Simplex Housings are available standard with a bypass valve, visual indicator, and SAE connections. Produced to be highly serviceable, our housing line provides the versatility for intermittent flow operations while offering a range of flow and pressure ratings compatible with inline pressurized systems and return line filtration.



Series 100 Simplex Housing

- Nominal working pressure – 900 PSI
- Visual indicator for element change out standard – 32 PSI
- Automatic bypass valve standard – 50 PSI Bypass Valve
- Operating temperature: -22°F to 248°F
- Max Flow: 5-10 gpm at 32 cSt*



Series 110 Simplex Housing

- Nominal working pressure – 450 PSI
- Visual indicator for element change out standard - 32 PSI
- Automatic bypass valve standard - 50 PSI Bypass Valve
- Operating temperature: -22°F to 248°F
- Max Flow: 25-50 gpm at 32 cSt*



Series 120 Simplex Housing

- Nominal working pressure - 4500 PSI
- Visual indicator for element change out standard - 72 PSI
- Automatic bypass valve standard - 101 PSI Bypass Valve
- Operating temperature: -22°F to 248°F
- Max Flow: 10-15 gpm at 32 cSt*



Series 130 Simplex Housing

- Nominal working pressure - 3000 PSI
- Visual indicator for element change out standard - 72 PSI
- Automatic bypass valve standard - 101 PSI Bypass Valve
- Operating temperature: -22°F to 248°F
- Max Flow: 30-60 gpm at 32 cSt*

*Using 25µm filter elements

All TTI Housings come standard with buna seals, viton available upon request.

PowerGuard™ TTHH 200 Series Duplex Housings

TTI Duplex Housings are available standard with a bypass valve, visual indicator, and SAE connections. Produced to be highly serviceable, our housing line provides the versatility for continuous flow operations while offering a range of flow and pressure ratings compatible with inline pressurized systems and return line filtration.



Series 200 Duplex Housing

- Nominal working pressure - 900 PSI
- Visual indicator for element change out standard - 32 PSI
- Automatic bypass valve standard - 50 PSI Bypass Valve
- Operating temperature: -22°F to 248°F
- Max Flow: 5-10 gpm at 32 cSt*



Series 210 Duplex Housing

- Nominal working pressure - 450 PSI
- Visual indicator for element change out standard - 32 PSI
- Automatic bypass valve standard - 50 PSI Bypass Valve
- Operating temperature: -22°F to 248°F
- Max Flow: 25-50 gpm at 32 cSt*



Series 220 Duplex Housing

- Nominal working pressure - 4500 PSI
- Visual indicator for element change out standard - 72 PSI
- Automatic bypass valve standard - 101 PSI Bypass Valve
- Operating temperature: -22°F to 248°F
- Max Flow: 10-15 gpm at 32 cSt*



Series 230 Duplex Housing

- Nominal working pressure - 3000 PSI
- Visual indicator for element change out standard - 72 PSI
- Automatic bypass valve standard - 101 PSI Bypass Valve
- Operating temperature: -22°F to 248°F
- Max Flow: 30-60 gpm at 32 cSt*

*Using 25µm filter elements

All TTI Housings come standard with buna seals, viton available upon request.

PowerGuard™ TTHH High Capacity Housings



TTHH-207 Housing

- 150 PSI working pressure
- 304 Stainless Steel
- Hinged lid for safe, ergonomic filter changeouts
- Max Flow 200 gpm
- Coreless

TTHH-107 Housing

- 150 PSI working pressure
- 304 Stainless Steel
- Hinged lid for safe, ergonomic filter changeouts
- Max Flow 200 gpm
- Coreless

TTHH-626 Housing

- 150 PSI working pressure
- 304 Stainless Steel
- Hinged lid for safe, ergonomic filter changeouts
- Max Flow 200 gpm

All TTI Housings come standard with buna seals, viton available upon request.



PowerBreather™ Desiccant Breathers

Protect your industrial systems from moisture and particulate intrusion with world-class desiccant breathers that extend equipment life and lower maintenance costs. All TTI PowerBreather desiccant breathers are produced using DuoGlass media, providing a significant performance upgrade over competing products.



PowerBreather™ Standard and CV (Check Valve) Desiccant Breathers

PowerBreather desiccant breathers provide a significant improvement over dust caps and stock OEM equipment breathers.

When contaminated air enters the top of the breather, it passes through layered filter media, preventing solid particles from causing undue wear to your equipment. The filtered air then passes through a bed of proprietary PowerGel that removes harmful moisture. The silica beads also work to attract moisture from inside the equipment reservoir during service or shut-down, keeping the system dry.



Standard Model

The PowerBreather Standard Model allows air to inhale and exhale freely, offering extremely high flows at reduced pressure drops.



CV Model

The PowerBreather Check Valve Model includes inflow/outflow check valves that protect silica gel media from humid and ambient conditions, extending breather life and optimal system performance.



Titan PowerBreather™ Desiccant Breathers

The Titan PowerBreather is the ideal desiccant breather solution for mobile equipment and high vibration applications, delivering a unique combination of increased flow capabilities, oil misting protection, and greater desiccant volume compared to standard offerings.

Our flagship Titan SmartFlow offers the highest net value on the market, combining increased service life in high humidity environments as well as added protection from oil misting conditions.

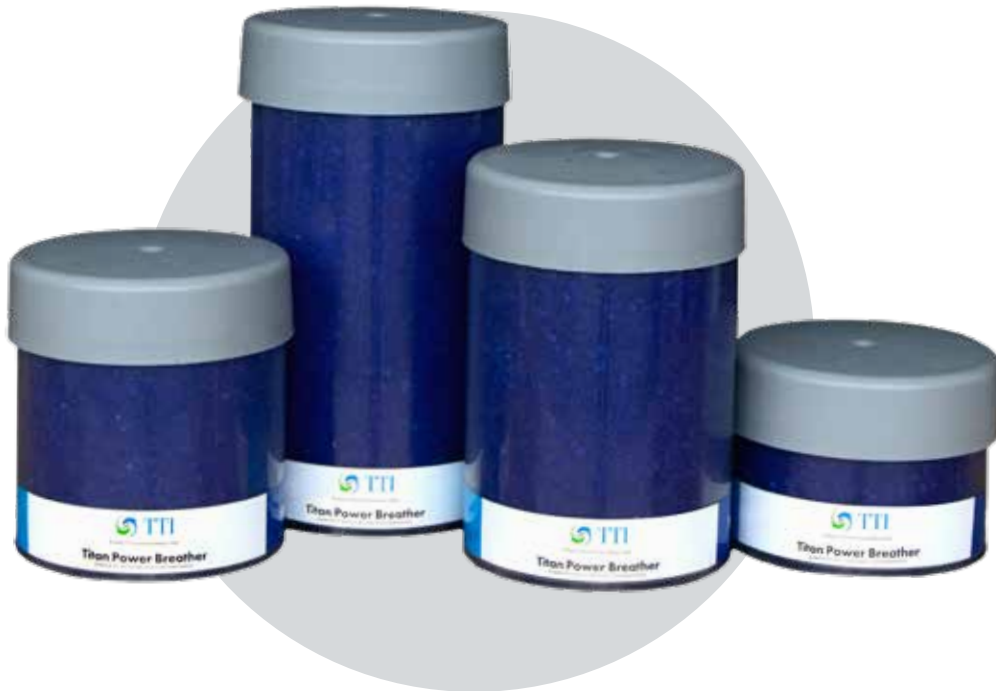



Check Valve Model

The Titan PowerBreather Check Valve Model includes inflow/outflow check valves that protect silica gel media from humid and ambient conditions, extending breather life and optimal system performance.



No Check Valve Model

The Titan PowerBreather No Check Valve model allows air to inhale and exhale without restriction, delivering the highest flow rates for a disposable breather on the market.



SmartFlow™ Model

The PowerBreather SmartFlow Adapter allows for exhaust of the outflow air prior to entering the breather, protecting the breather from oil mist and system humidity and ensuring even longer breather life.

TitanBlock PowerBreather™ Desiccant Breathers

Reloadable cartridges that deliver a direct upgrade over OEM designs with superior filtration, higher efficiency, and greater dirt holding capacity.



Orange Silica Gel

Proven in both the lab and the field to provide industry-leading moisture capacity.

Oil Mist Collector

Nylon foam traps oil mist, protecting breather media (and thus your systems) from contamination.

Check Valve (Optional)

Allows outflow air to rapidly evacuate the breather body without contacting silica gel media, preventing premature saturation and eliminating the chance for oil mist to degrade system performance.

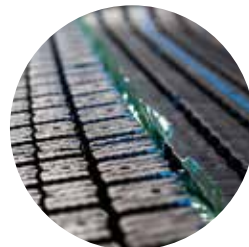

Rebuildable PowerBreather™ Desiccant Breathers

The TTI Rebuildable PowerBreather offers the ability to remove both particulate and moisture in high-flow and extreme humidity environments. Our 304 stainless steel rebuild kit also retrofits the industry standard design.

While in service, the Rebuildable PowerBreather eliminates moisture and particulate intrusion into the system. During shutdown, the PowerBreather silica gel attracts moisture and actively dries the system.



Rebuildable Kit

Replacement Filter Cartridge: Pleated microglass filter cartridge captures airborne contaminants to 1 micron absolute.

Desiccant Bag Filter: Polypropylene bag has handles for easy removal and replacement.

Sight Glass Indicator: Silica gel changes color from blue to pink when the unit requires rebuilding.

Note: Rebuild kit also includes lid gasket, sight glass gasket and oil dispersing foam pad.

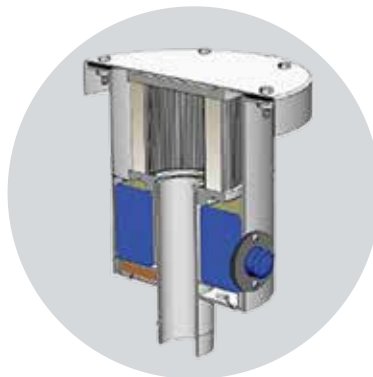

PowerBreather™ Adapter Kits

Keeping your hydraulic systems, gear boxes, totes and drums clean, dry, and in optimal operating condition is a challenge for every maintenance professional. By featuring a single manifold body, TTI PowerBreather Adapter Kits improve handling practices while minimizing contaminant entry.





Hydraulic Adapter Kit

Includes:

- Adapter body
- Fitting, ISO B 3/4" male
- Fitting, ISO B 1" male
- Vacuum Gauge
- Sample Valve
- Gasket, 6-hole ANSI
- Fill tube, 12" length



Gearbox Adapter Kit

Includes:

- Gearbox adapter body
- Fitting, ISO B 3/4" male
- Fitting, ISO B 1" male
- Fitting, 3/4" FNPT
- Vacuum Gauge
- Fill tube, 2" length



Drum Adapter Kit

Includes:

- Adapter Body
- Fitting, ISO B 3/4" male
- Fitting, ISO B 1" male
- Return Line, 9" length
- Suction Line, 38" length



Tote Adapter Kit

Includes:

- Adapter Body
- Fitting, ISO B 3/4" male
- Fitting, ISO B 1" male
- Fitting, Wye 1"
- Return Line, 9" length

Cross Reference Tool

The TTI cross reference tool helps you identify the most suitable PowerBreather or PowerGuard filter element. Follow the link below and enter an OEM part number to get started.

www.toddtechinc.com/cross-reference/



The screenshot shows the TTI Cross Reference Tool web page. The header includes navigation links: About Us, Products, Sizing Tool, TTI (Service Quality Innovation), Cross Reference, Resources, and Contact. The main heading is "Cross Reference Tool" with a sub-heading: "The TTI cross reference tool helps you identify the most suitable TTI product by entering a competitor part number." Below this is a form with the instruction: "Please enter a competitor product number and click submit. *Must contain at least 3 characters. **No need to include spaces or dashes when searching for part numbers." There is a search input field and a green "Submit" button. The footer contains the TTI logo and navigation links: TODD TECHNOLOGIES INC. - TTI - ABOUT US - PRODUCTS - CROSS REFERENCE - RESOURCES - CONTACT - BLOG - SITEMAP, along with a "CONTACT US" button.

30

Sizing Tool

The TTI sizing tool helps you identify the most suitable PowerBreather™ for your applications. The tool also provides references to product pages when needed. Follow the link below to get started.

www.toddtechinc.com/sizing-tool/



The screenshot shows the TTI Sizing Tool web page. The header includes navigation links: About Us, Products, Sizing Tool, TTI (Service Quality Innovation), Cross Reference, Resources, and Contact. The main heading is "Sizing Tool" with a sub-heading: "The TTI Sizing Tool helps you identify the most suitable TTI PowerBreather™ for your application & operation. The tool also provides references to product pages when needed." Below this is a form with the instruction: "What is the Application?" and a search input field with the placeholder text "Search The Application". The footer contains the TTI logo and navigation links: TODD TECHNOLOGIES INC. - TTI - ABOUT US - PRODUCTS - CROSS REFERENCE - RESOURCES - CONTACT - BLOG - SITEMAP, along with a "CONTACT US" button.

TTI Team Members Are Always Available to Help



Derek Kula

VP of Business Development: MLT 1

Office: +1.303.585.0132

Cell: +1.949.335.2438

Email: derek@toddttechinc.com



Dustin Flynn

Account Manager, US East: MLT 1

Office: +1.303.585.0132

Cell: +1.949.563.3003

Email: dustin@toddttechinc.com



Christian Stapen

Account Manager, US West: MLT 1

Office: +1.303.585.0132

Cell: +1.303.638.7939

Email: christian@toddttechinc.com



David Filloy

Director of Sales, Latin America: MLT 1

Office: +1.303.585.0132

Cell: +506.8844.1688

Email: david.filloy@toddttechinc.com



Wolfgang Stausberg

Managing Director, Europe

Office: +1.303.585.0132

Cell: +49(0)151.74520493

Email: wolfgang@toddttechinc.com



TTI

Service • Quality • Innovation